

INSTRUCTION BOOK
for
MODEL 300H-U7
SENSITIVE ELECTRONIC VOLTMETER

300 μ V — 330 V

10 cps — 1.0 Mc



Contract No. N600 (24-126) 65422

Fed. Stock No. 2F6625-839-8012

BALLANTINE LABORATORIES, INC.

BOONTON, NEW JERSEY

APPROVED 9 FEBRUARY 1967

INSTRUCTION BOOK CONTENTS
FOR
MODEL 300H-U7 SENSITIVE ELECTRONIC VOLTMETER

| | |
|---|----|
| 1. SPECIFICATIONS .. | 1 |
| 2. GENERAL | 2 |
| 3. OPERATION | 2 |
| 3.1 Function of Controls | 2 |
| 3.2 Power Connections and Warmup | 2 |
| 3.3 Voltage Measurement | 2 |
| 3.4 Effect of DC Signal Component | 3 |
| 3.5 Overload Considerations | 3 |
| 3.6 Ground Current Considerations | 3 |
| 3.7 Input Impedance | 3 |
| 3.8 Use as Amplifier | 3 |
| 3.9 Use as Null Detector | 4 |
| 3.10 Measurements from 50 to 500 Microvolts | 4 |
| 3.11 Current Measurement | 4 |
| 4. CIRCUIT DESCRIPTION | 4 |
| 4.1 Input Attenuator | 4 |
| 4.2 Amplifier | 5 |
| 4.3 Rectifier-Meter Circuit | 5 |
| 4.4 Power Supply | 6 |
| 5. MAINTENANCE | 6 |
| 5.1 General Instructions | 6 |
| 5.1.1 Fuse and Pilot Lamp Replacement | 6 |
| 5.1.2 Line Voltage Conversion | 6 |
| 5.2 Periodic Checks | 6 |
| 5.2.1 Equipment Required | 6 |
| 5.2.2 2,000 Hours Operation Check | 6 |
| 5.2.3 4,000 Hours Operation Check | 6 |
| 5.3 Performance Checks | 7 |
| 5.3.1 Attenuator Decoding | 7 |
| 5.3.2 Scale Adjustment | 7 |
| 5.3.3 Sensitivity Adjustment | 8 |
| 5.3.4 High Frequency Response | 8 |
| 5.3.5 Low Frequency Response | 9 |
| 5.3.6 SENS X10 Performance | 9 |
| 5.4 Trouble Shooting | 9 |
| 5.4.1 Equipment Required | 9 |
| 5.4.2 General Malfunction | 10 |
| 5.4.3 Signal Tracing | 10 |
| 5.4.4 Power Supply Malfunction | 11 |
| 5.4.5 Trouble Shooting Chart | 11 |
| 6. SHIPPING INSTRUCTIONS | 12 |
| 7. REPLACEMENT PARTS LIST | 13 |

FIGURES

| | |
|--|------|
| 1. Ballantine Model 300H-U7 Sensitive Electronic Voltmeter | III |
| 2. Typical Input Resistance vs. Frequency | 3 |
| 3. Typical Frequency Response of SENS X10 Function | 4 |
| 4. Attenuator, Simplified Schematic | 5 |
| 5. Instrument Adjustments | 7 |
| 6. Frequency Response Check | 8 |
| 7. Ballantine Model 300E1-U7 Interior View — Left Side | Rear |
| 8. Ballantine Model 300H-U7 Interior View — Right Side | Rear |
| 9. Schematic Diagram Model 300H-U7 | Rear |

TABLES

| | |
|---|----|
| I Maximum Overload Ratios | 3 |
| II Input Capacitance vs. Range Switch Setting | 3 |
| III Attenuator Ratios | 4 |
| IV Tube Element Potentials..... | 10 |

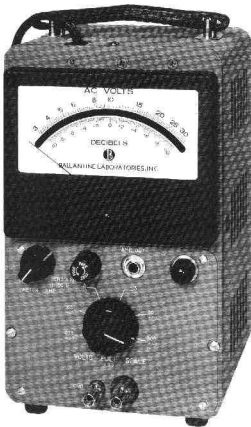

Figure 1 — Ballantine Model 300H-U7

1. SPECIFICATIONS

BALLANTINE MODEL 300H-U7 SENSITIVE ELECTRONIC VOLTMETER

Voltage Range

300 μ V to 330 V in 6 ranges
30 μ V to 300 μ V in SENS X10 position of function switch,
with range selector switch in .003 position

Decibel Range

70 db to +150 db Ref 1 V

Frequency Range

10 cps to 1 Mc, 300 μ V to 330 V
100 cps to 100 kc, 30 μ V to 300 μ V

Accuracy

10 cps to 700 kc \pm 2.0%
700 kc to 1 Mc \pm 3.0%
at all points on scale

SENS X10

Sensitivity — 30 μ V minimum indication
Frequency range — 100 cps to 100 kc
Accuracy — \pm 5.0% of indication
(Measurements from 10 cps to 1 Mc may be
made with reduced sensitivity and accuracy.)

Input Impedance

0.003 V range 2 M Ω shunted by 25 pF
All other ranges 2 M Ω shunted by 15 pF

Stability

Expected calibration stability 5,000 hrs. operation
Recommended calibration period 2,000 operating hrs
Effect of tube change negligible
Change in indication with line voltage variation of 105 V
to 125 V:
20 cps — 500 kc \pm 0.25% max
10 cps — 700 kc \pm 0.50% max
10 cps — 1 Mc \pm 0.75% max

Scales

Logarithmic voltage scale from 3 to 33
Linear decibel scale from -10 to +10

Amplifier Characteristics

Maximum voltage gain 40 db \pm 0.5 db
Maximum output voltage 0.3 V
Frequency response \pm 1 db, 10 cps to 1 Mc
with maximum loading
Output impedance 3 ohms
Maximum loading 5,000 ohms and 50 pF
Equivalent input noise (input open) 25 μ V max

Power Supply

115/230 V, 50 — 420 cps, 35 W approximately

Standard Finish

Panel, gray crackle; box, gray wrinkle

Dimensions (inches)

Portable: 11" H, 6" W, 7" D

Weight

Portable: Instrument alone 10 lbs.
Packed for shipment 20 lbs.

2. GENERAL

The Model 300H-117 AC Voltmeter has been designed to permit high-accuracy measurements of ac potentials over its specified frequency and voltage range. In addition to the primary function, the instrument may also be used as a high-gain, wide-band amplifier, or as a very sensitive null indicator. With accessory shunt resistors (Ballantine Laboratories, Inc. Model 600 Series) the instrument may also be employed as a sensitive accurate current indicator.

Basically the instrument consists of a high-impedance input attenuator followed by a degeneratively-stabilized amplifier which feeds a signal rectifier and meter circuit. All necessary operating potentials are obtained from a simple line operated power supply.

A most important feature of this as well as other Ballantine Voltmeters is its logarithmically-graded voltage scale, which provides the same high accuracy of indication **at all points on the scale**. The associated linear decibel scale provides

an automatic conversion of voltage ratios to decibel units, eliminating computation or reference to charts or tables.

The signal rectifier in this instrument is of the average-responding type, i.e., the indications are proportional to the area under the wave form being measured. The indication, however, is calibrated rms in terms of a sine wave. When the wave form departs from a sinusoid this arrangement provides indications far closer to the true rms value than a similarly calibrated peak-responding circuit.

In the electrical design of this instrument, emphasis was placed on providing the maximum utility consistent with reliability and low cost. To these ends all components were initially chosen to withstand anticipated environmental conditions, and are operated well below their maximum ratings. In the mechanical design, emphasis was placed on ruggedness and accessibility. Stringent performance checks conducted at Ballantine Laboratories, Inc. indicate that a long life, with freedom from frequent recalibrations and servicing, may be expected.

3. OPERATION

3.1 Function of Controls

The controls necessary for the operation of this instrument are (see Fig. 1):

| CONTROL | POSITION | PURPOSE |
|-------------------|---------------------------------|--|
| Function Selector | OFF | Turns power off |
| | METER | Turns power on and selects vacuum tube voltmeter mode of operation |
| | AMP | Selects amplifier mode of operation with output available at AMP OUT jack |
| | SENS X10 | Selects vacuum tube voltmeter mode of operation with sensitivity increased by a factor of 10, over a reduced frequency range |
| Range Selector | 0.005 — 300 VOLTS FULL SCALE | Attenuates input signal and indicates volts full scale |

3.2 Power Connection and Warmup

Connect the power cord to a source which conforms with the requirements stated on the decal located where the line cord leaves the instrument case. Rotate the Function Selector to either the METER, AMP, or SENS X10 position and note that the pilot lamp lights. Allow a warmup period of at least 5 minutes, unless the instrument has not been in use for many months, in which case allow an initial warmup period of at least 30 minutes.

IT IS IMPORTANT THAT AIR BE ALLOWED TO CIRCULATE FREELY AT ALL SIDES OF THE INSTRUMENT AND THAT NO SOURCES OF HEAT BE PLACED DIRECTLY AGAINST THE INSTRUMENT CASE.

3.3 Voltage Measurement

Rotate the Function Selector to the position marked METER. Connect the voltage to be measured to the input terminals, observing the **ground** polarization. Rotate the Range Selector until an on scale indication is observed. The position of the range knob, together with the meter indication, gives the value of the voltage at the input terminals.

For greatest accuracy the instrument should be used in its vertical position, the position in which it is calibrated at Ballantine Laboratories, Inc. When used in the horizontal position, balance error in the indicator may result in reduction of accuracy. This effect, if present, is usually greatest at the low end of the scale and may be reduced by a readjustment of the Scale Adjustment as outlined in Section 5.3.2.

Although great precautions in design and construction have been taken to minimize the inherent hum in this instrument, signal of the line frequency amounting to several microvolts referred to the input terminals may be present. If the highest accuracy is needed when making measurements of signals at line frequency, the average of the two indications obtained with the line plug in both its positions should be taken.

3.4 Effect of DC Signal Component

An input coupling capacitor, in series with the high input terminal of the instrument, effectively blocks any dc signal component unless it should become excessively large. If the dc component exceeds 600 volts (dc working voltage of the input capacitor), an additional blocking capacitor, with the necessary dc working voltage may be placed in series with the input terminal. At low frequencies the value of this capacitance must be large enough ($>0.1 \mu\text{F}$ at 10 cps) to prevent degradation of the low frequency accuracy of the voltmeter.

3.5 Overload Considerations

Although the instrument is designed to withstand rather severe overloads without damage, there are limits to the amount of overloading which may be safely imposed. In general, on the lower ranges, this is dictated by the maximum grid voltage which the amplifier input tube can withstand without damage. On the higher ranges the maximum voltage rating of components in the input attenuator restricts the maximum voltage which may be safely applied. Table I below lists the maximum overload ratios for the various ranges.

TABLE I

| MAXIMUM OVERLOAD RATIOS | | |
|-------------------------|----------------|---------------|
| Range | Overload Ratio | Maximum Input |
| 0.003 Volt | 100,000 to 1 | 300 Volts |
| 0.03 Volt | 10,000 to 1 | 300 Volts |
| 0.3 Volt | 1,000 to 1 | 300 Volts |
| 3.0 Volts | 100 to 1 | 300 Volts |
| 30.0 Volts | 10 to 1 | 300 Volts |
| 300.0 Volts | 1 to 1 | 300 Volts |

3.6 Ground Current Considerations

A common source of error when making low level measurements is ground current, i.e., a current of signal, line, or other frequency flowing in a ground lead impedance, which results in a voltage in addition to the desired signal voltage, appearing at the input terminals of the voltmeter. The effect of such a current may be eliminated or reduced by:

- eliminating the ground current
- employing a low capacitance, high insulation-resistance isolation transformer between the power line and the voltmeter

- employing as far as possible only coaxial connecting leads in the signal circuits leading to the voltmeter input terminals
- making all ground lead impedances as low as possible.

3.7 Input Impedance

The input impedance of this instrument may be represented as a parallel combination of resistance and capacitance.

The capacitive component is essentially independent of frequency but is a function of the range switch setting, and is given in Table II.

TABLE II

| INPUT CAPACITANCE VS. RANGE SWITCH SETTING | |
|--|-------------|
| Range | Capacitance |
| 0.003 Volt | 25 pF |
| 0.03 Volt | 15 pF |
| 0.3 Volt | 15 pF |
| 3.0 Volts | 15 pF |
| 30.0 Volts | 15 pF |
| 300.0 Volts | 15 pF |

The resistive component (2 megohms, $\pm 2\%$) is independent of range switch setting at the lower frequencies, but is a function of both range and frequency at the higher frequencies and is shown in Fig. 2.

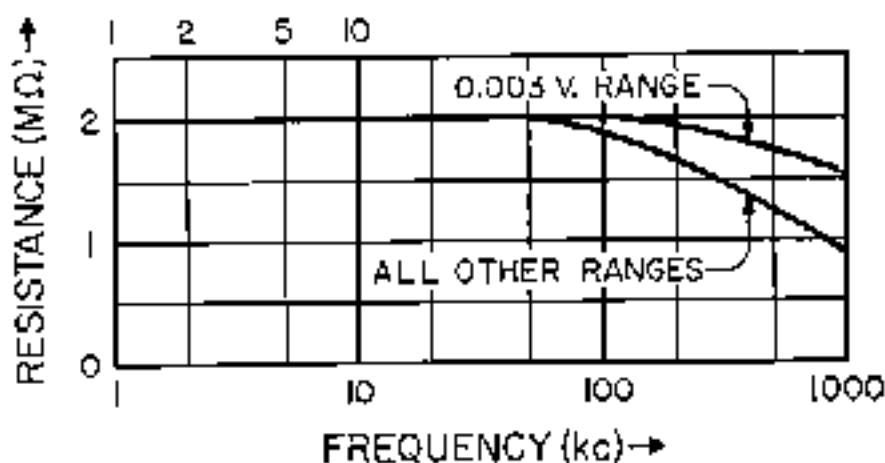

Fig. 2. Typical Input Resistance vs. Frequency

3.8 Use as Amplifier

Rotate the function selector to the position marked AMP. Connect the signal to be amplified to the input terminals, observing ground polarization. Rotate the range selector to the range which would be used in measuring the input voltage. The output is now available at the output jack located on the front panel and marked AMP OUT.

The maximum voltage gain of the amplifier is 40 db, reducible in steps of 20 db by means of the range selector.

The maximum output voltage available is 0.3 volts, while the output impedance is approximately 3 ohms at mid-band frequencies. A distortion free output is obtainable with load impedances as low as 5,000 ohms. The open circuit noise level referred to the input terminals will in general be under 25 microvolts for all ranges. The response of the amplifier is flat within 1 db over the range of 10 cps to 1 Mc for load impedances of not less than 5,000 ohms.

3.9 Use as Null Detector

When employing this voltmeter as a null indicator, the case may arise where the signal level falls below 300 microvolts; this would take the indicator off the low end of the scale on the most sensitive range. Rotating the function selector to the SENS X10 position increases the sensitivity by a factor of 10 permitting null indications to below 30 microvolts over most of the frequency range.

3.10 Measurements from 30 to 300 Microvolts

Rotating the Range Selector to the most sensitive (0.003 volt) range and setting the Function Selector to the SENS X10 position, permits measurements over the range of 30 to 300 microvolts. Since the increase in sensitivity is achieved at the expense of loop feedback, the accuracy, stability, and frequency range in this mode of operation are all reduced. The overall accuracy over the frequency range of 100 cps to 100 kc will be within $\pm 5.0\%$; for response at points above 100 kc and below 100 cps see Fig. 3. The noise level

in this mode of operation will be 12 microvolts or less referred to the input terminals.

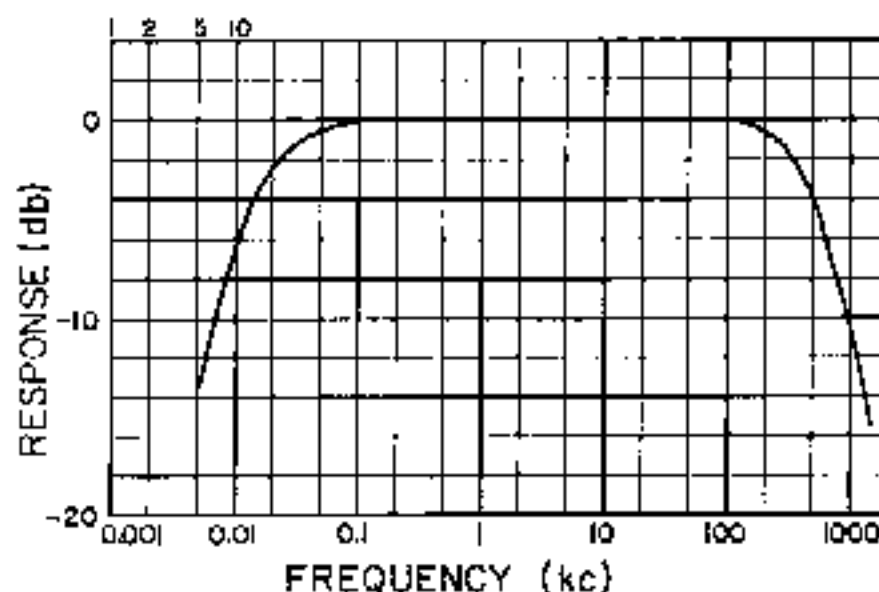

Fig. 3. Typical Frequency Response of SENS X10 Function

3.11 Current Measurement

By using the Ballantine Series 600 Precision Shunt Resistors in conjunction with this voltmeter it is possible to measure ac currents from 0.03 microampere to 10 amperes. For a complete description of the accuracy, current, and frequency range of these shunt resistors, refer to the Ballantine catalog.

4. CIRCUIT DESCRIPTION

A schematic diagram and replacement parts list are included at the end of this instruction book. All references to schematic symbols in the following sections are to these, or to Fig. 4.

4.1 Input Attenuator

Since the amplifier of the Model 300H-U7 always operates with the same basic sensitivity (0.0003 volt to 0.003 volt), an attenuator must be provided for reducing higher level voltages to this range.

Actually the input attenuator of the Model 300H-U7 consists of three separate attenuators. The first provides a reduction of 10 to 1; the second, 100 to 1; the third, 1000 to 1, 10,000 to 1 and 100,000 to 1. Table III is a listing of range selector settings and attenuation ratios.

At very low frequencies the attenuation ratio is determined solely by the resistors employed. At the higher frequencies, capacitive compensation is necessary to compensate for circuit strays, input capacitance of the amplifier, etc. The cross-over from resistive to capacitive attenuator occurs at approximately 25 kc. Fig. 4 is a simplified schematic of all three attenuators showing component values. The high frequency

response of attenuator No. 1 is adjustable by means of C2, the response of No. 2 by C3, the response of No. 3 by C4. Thus C4 serves to adjust the high frequency response of all three steps of attenuator No. 3.

TABLE III

| ATTENUATOR RATIOS | |
|-------------------|-------------------|
| Range | Attenuation Ratio |
| 0.003 Volt | 1 |
| 0.03 Volt | 10 |
| 0.3 Volt | 100 |
| 3.0 Volts | 1,000 |
| 30.0 Volts | 10,000 |
| 300.0 Volts | 100,000 |

Note: The user is cautioned against making any adjustments of C2, C3 or C4 without first reading Section 5.3.4.

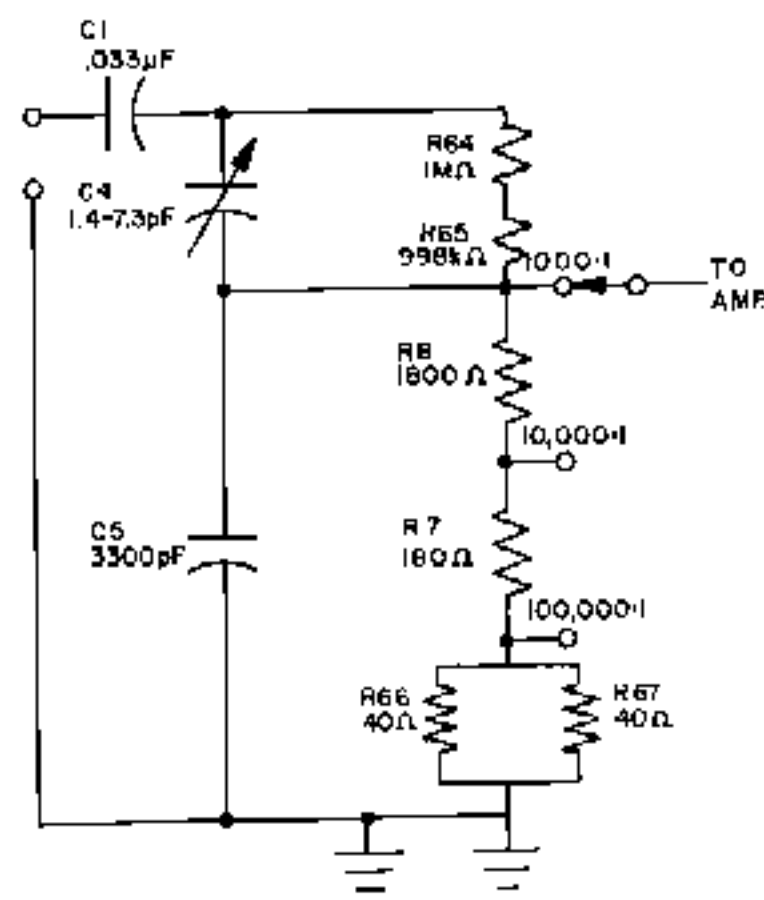
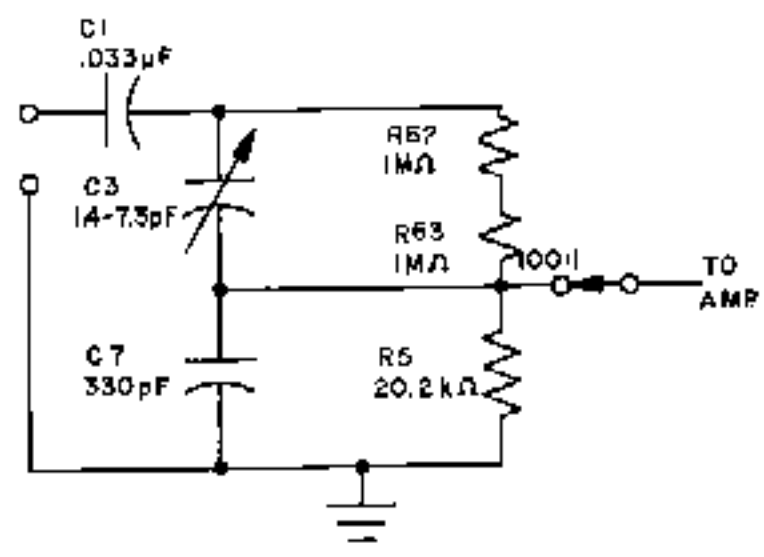
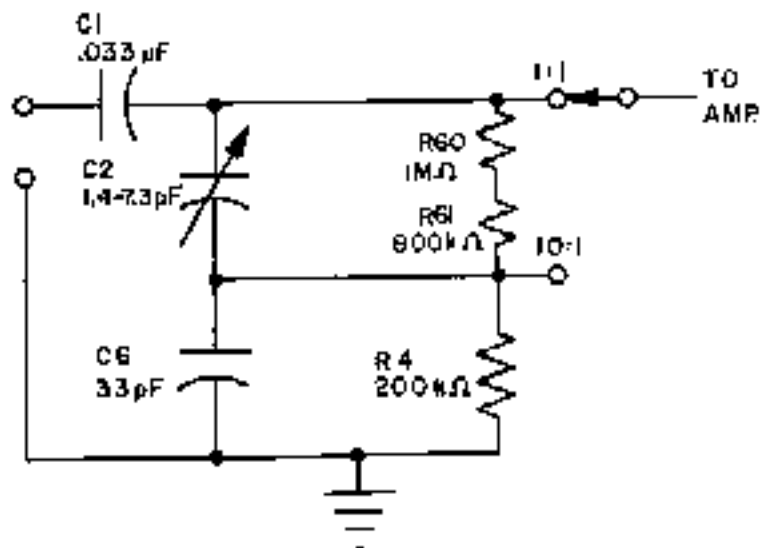

Fig. 4. Attenuator, Simplified Schematic

4.2 Amplifier

The amplifier consists of four capacitively coupled pentode stages. The first three stages are operated to provide voltage gain while the final stage is used as a transducer to convert voltage to current for the rectifier-meter circuit. When the instrument is operated in its AMP position the fourth stage also provides voltage gain.

Local feedback (achieved by unbypassed cathode resistors) as well as overall feedback (37 db or greater) is employed to minimize distortion and gain changes from whatever cause. The amplifier response without feedback is shaped to fall off from the mid-band value at a rate of approximately 6 db per octave. As a result of this and the amount of feedback available, the stability of the amplifier at the band extremes (10 cps and 1 Mc) is essentially that of mid-band.

In the SENS X10 position, the basic sensitivity of the instrument is increased 10 \times by reducing the loop feedback, with an attendant reduction in bandwidth and stability.

The high frequency response of the instrument is adjustable over a narrow range by means of L1. See Section 5.3.4. The gain or sensitivity of the instrument is adjustable over a small range by means of R10 in the feedback network; R40 adjusts the sensitivity of the SENS X10 function. See Section 5.3.3.

The heater of the input amplifier stage is operated on dc to minimize the line frequency component injected in this low level stage. Thus the error introduced when measuring voltages of line frequency and its harmonics is substantially reduced.

4.3 Rectifier-Meter Circuit

AC current, supplied by the last amplifier stage, is passed through the rectifier-meter circuit and the feedback network to ground.

The rectifier is of the full wave, bridge-type employing semiconductor diodes. Direct current from it passes through Meter M1. The capacitor across M1 serves to reduce the indicator flutter at the lower frequencies. The response of the circuit is average, although the meter is calibrated RMS in terms of a sine wave.

Resistors R43 and R44 provide for an adjustment of the meter indication at 3 on scale. See Section 5.3.2. A small current, determined primarily by the value of R44 and the potential at the top of the rectifier circuit with respect to ground, is passed down through the rectifier circuit. The division and direction of this current through the meter is determined by the position of R43.

The forward and reverse conductance of all semiconductor diodes is a function of their operating temperature (in addition to other factors) and is therefore influenced by ambient temperature. In the operation of this instrument this effect manifests itself as a small change in indication during the warmup period, the effect being largest for down-scale indications. To reduce this effect a third diode of the same type as the signal unit is employed in a compensating network consisting of R37, R39 and CR1.

The signal rectifiers are of a hermetically-sealed, gold-bonded type and are virtually immune to aging and environmental conditions. The inherently non-linear characteristic of this diode is reduced to negligible proportions by incorporating the rectifier circuit within the feedback loop.

The indicating meter is of special design, employing shaped pole pieces to achieve a logarithmic voltage indication.

4.4 Power Supply

Amplifier plate and screen voltages are obtained from a full wave vacuum tube rectifier employing an rc filter, and gaseous regulator tube. Low voltage dc power for the first amplifier stage heater is obtained from a full wave rectifier employing hermetically sealed silicon junction diodes, and a capacitance filter. All other amplifier heaters are operated on ac balanced with respect to ground.

5. MAINTENANCE

Servicing of the instrument by the user is feasible, providing the procedures outlined in this section are followed. However, it cannot be too strongly emphasized that the work should be entrusted only to technicians having the highest skill and experience in measurement techniques. A refined and comprehensive method of recalibration is beyond the scope of this manual and cannot be effected without specialized equipment having an order of accuracy much greater than that of the instrument being checked. Such equipment and personnel trained in its use are available in the Calibration Department of Ballantine Laboratories, Inc. If trouble develops which cannot be corrected except by the replacement of special components, or if the user is not equipped with the necessary test equipment, it is recommended that the instrument be returned to Ballantine Laboratories, Inc. for servicing. The instrument should in all cases be preceded by a letter indicating the fault or desired service and/or recalibration. (See Section 6. Shipping Instructions.)

5.1 General Instructions

5.1.1 Fuse and Pilot Lamp Replacement

The fuse is of the Slo-Blow type and is rated at 0.4 ampere for 115 volt operation and 0.2 ampere for 230 volt operation. The fuse holder is of the extractor-post type and is located on the front panel.

The pilot lamp, Type 1815, is accessible by unscrewing the red plastic cap located on the front panel.

5.1.2 Line Voltage Conversion

It is possible to operate the Model 300H-U7 from either a 115 volt or 230 volt line supply. The line voltage for which the instrument is connected on leaving the factory is indicated on a decal located adjacent to the power cord emergence point. To convert from 115 volt to 230 volt operation, or vice versa, see the schematic diagram located at the back of this manual.

5.2 Periodic Checks

5.2.1 Equipment Required

- a. A stable, distortion-free, and accurately calibrated source of voltage with a signal frequency in the range of 400-1000 cycles. Output of the source should be continuously variable over a range of at

least 0.3 millivolt to 10.0 volts. The Ballantine Model 420 or 421A Precision Calibrator (refer to Ballantine Catalog) is such a source of voltage.

- b. A stable, distortion-free, variable frequency signal generator covering a range of at least 10 cps to 1 Mc. The output should be variable over a range of at least 500 microvolts to 3.0 volts.
- c. A stable, sensitive, flat-responding voltmeter covering a range of at least 10 cps to 1 Mc and a voltage range of 300 microvolts to 300 volts. For highest accuracy the Ballantine Model 440 Micropotentiometer and Model 393 HF Transfer Voltmeter are recommended. In the event that these are not available another Ballantine Model 300H-U7 known to be in calibration may be used.

5.2.2 2,000 Hours Operation Check

At the end of each 2,000 hours or 1 year of operation it is recommended that the checks outlined in the following sections be made:

- 5.3.1 Attenuator Decoding
- 5.3.2 Scale Adjustment
- 5.3.3 Sensitivity Adjustment
- 5.3.4 High Frequency Response
- 5.3.5 Low Frequency Response
- 5.3.6 SENS X10 Performance

5.2.3 4,000 Hours Operation Check

At the end of each 4,000 hours or 2 years of operation it is recommended that all vacuum tubes be checked, replaced as necessary, and the checks outlined in the following sections be made:

- 5.3.1 Attenuator Decoding
- 5.3.2 Scale Adjustment
- 5.3.3 Sensitivity Adjustment
- 5.3.4 High Frequency Response
- 5.3.5 Low Frequency Response
- 5.3.6 SENS X10 Performance

5.3 Performance Checks

5.3.1 Attenuator Decoding

When the signal input to the instrument is increased or decreased by precise factors of 10, and the range selector changed accordingly, the indication of the instrument should not vary by more than $\pm 0.2\%$. Thus, if the instrument is indicating 1.0 on a given range, increasing the input by a factor of 10 ($\pm 0.05\%$) and switching to the next higher range should produce an indication of 1.0 ($\pm 0.2\%$). Decoding checks should be made with an undistorted sine wave signal of mid-band frequency (400 to 1,000 cycles).

There are no controls or adjustments relating to the attenuator decoding, this factor being solely determined by the attenuator resistors. If it is discovered that the decoding is in error, in all probability one or more of the attenuator resistors has changed in value. However, some other possible sources of difficulty are:

- grid current in the amplifier input tube V1
- misadjustment of Capacitors C2, C3 or C4.

Note: No adjustment of these should be made without reference to Section 5.3.4.

The resistors employed in the attenuator are a film type of advanced design, exhibiting a stability approaching that of wire wound units, but free from the reactive effects inherent in the latter. Initially the resistor values are matched to a tolerance of $\pm 0.2\%$, in addition to which the temperature coefficients of the various values are closely matched. In view of the above it is recommended that the user make no resistor replacements, except perhaps as an emergency measure on a temporary basis. It is recommended that the instrument be returned to Hallamrine Laboratories, Inc. for servicing.

5.3.2 Scale Adjustment

When an undistorted sine wave signal produces a deflection of precisely 30 on a given range, switching to the next higher range should produce a deflection of precisely 3.0 on scale. During its calibration at Hallamrine Laboratories, Inc. the instrument is very carefully adjusted for this condition, and it should seldom be found necessary to readjust. In the event that readjustment does become necessary, the control relating thereto is R43, and is available through an access hole in the right-hand side of the instrument case. See Fig. 5.



Fig. 5 Instrument Adjustments

Access to L1, R40, C2, C3, and C4 is obtained by removing the two knobs, and then the engraved escutcheon plate. Note—Read sections 5.3.2, 5.3.3, 5.3.4, and 5.3.6 before adjusting any of the above.

To make the scale adjustment, first allow the instrument to warm up completely. Then connect an undistorted sine wave of mid band frequency (400 - 1000 cycles) to the input terminals and adjust the amplitude for an indication of precisely 3.0 on any range (except the 300 volt range). Switch the instrument range selector to the next higher range. The indication should be precisely 3.0. Because of the relatively high damping at the low end of the meter scale, sufficient time should be allowed to permit the indicating needle to come to its final position. It is also recommended that the meter be tapped lightly to remove any effects of pivot friction. If the indication is not precisely 3.0, correct by means of control R43. Recheck and readjust if necessary.

5.3.3 Sensitivity Adjustment

The design of this instrument is such that it should maintain its accuracy over extended periods of time and use. At Ballantine Laboratories, Inc. this accuracy is very carefully adjusted and checked. Moreover, an attempt is made to distribute the various inherent errors, so that the best possible overall accuracy results. The user, therefore, is cautioned against making any readjustments without fully determining that the instrument is in error.

All checks of sensitivity should be made with an undistorted sine wave at a mid-band frequency (400 - 1000 cycles). The external standard meter, if used, should be accurate to 0.25% or better, and preferably of the RMS responding type.

If it has been established that the instrument is in error, the first attempt at correction should be tube replacement.

If tube replacement does not restore accuracy place the original tubes back in the instrument. A small adjustment is possible with control R10, available through an access hole in the left hand side of the case. See Fig. 5. A larger adjustment is available by changing the value of R13, although the necessity to change this value may be an indication that something else is at fault in the instrument.

5.3.4 High Frequency Response

A discussion of all the factors entering into the high frequency response of this instrument is beyond the scope of this manual. There are, however, a number of adjustments connected with this response and a procedure for making these adjustments will be outlined. All checks of response must be made with a distortion-free (if possible, less than 1%) sine wave signal, and the instrument used as a reference must have an extremely low error (preferably less than 0.25%) over the range of 1,000 cps to 1 Mc. The Ballantine Model 440 Micropotentiometer and Model 393 HF Transfer Standard are recommended for this purpose; in the event that these are not available another Ballantine Model 300H U7 known to be in calibration may be used.

To check the response of the instrument connect together the instruments as shown in Fig. 6. Set the

signal generator to a frequency of 1,000 cps, the output to a level consistent with the range of the Model 300H-U7 to be checked, and the level monitor for a suitable indication. Note the indication on both the Model 300H-U7 and the level monitor. Next set the signal generator to frequencies of 10 kc, 100 kc, 700 kc and 1 Mc, in each case keeping the indication on the level monitor the same as it was at 1,000 cps and noting the indications of the Model 300H-U7 being checked.

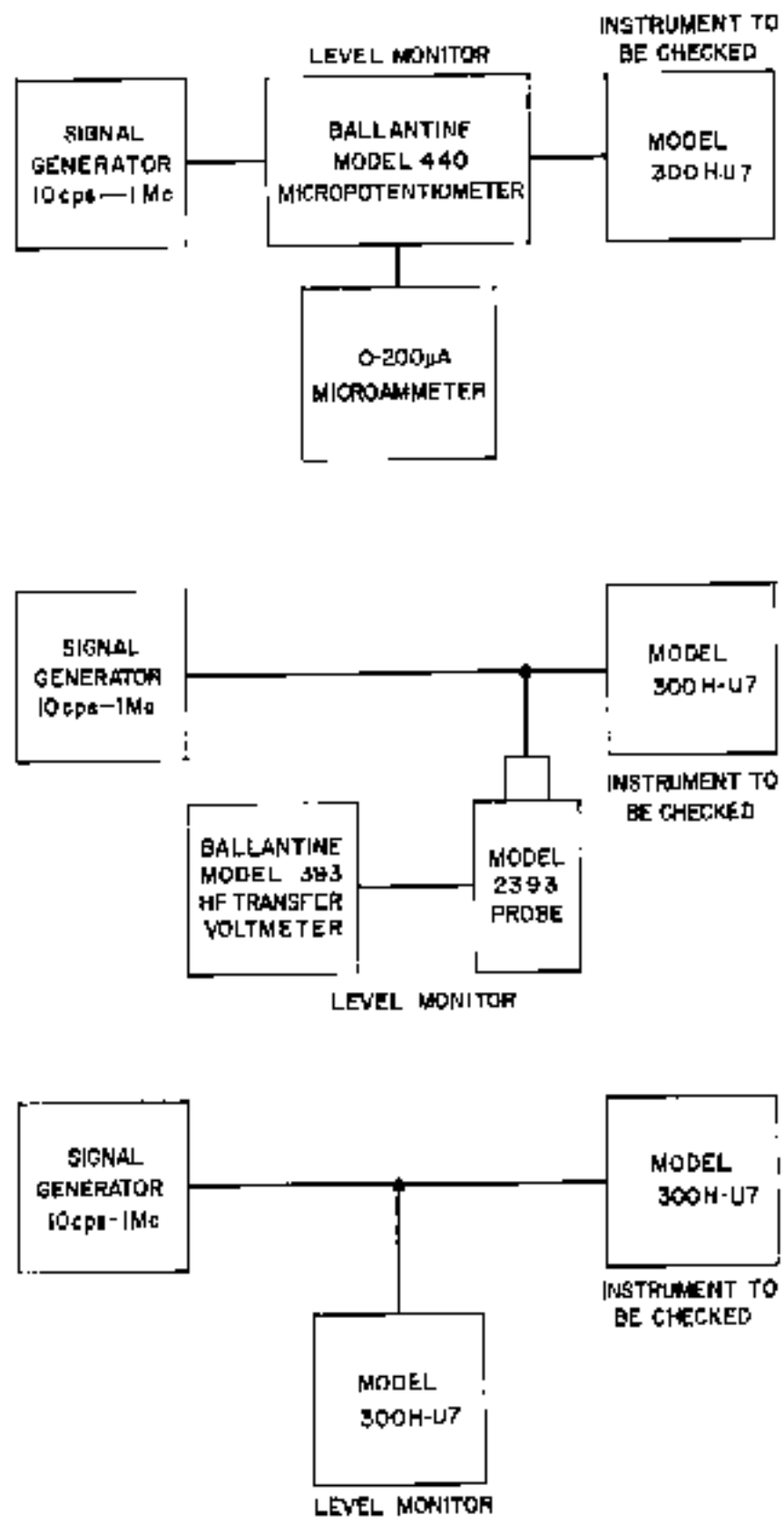

Fig. 6. Frequency Response Check

If by this procedure it is determined that the instrument is in error at the higher frequencies, the first attempt at correction should be tube replacement. If tube replacement does not restore normal response, place the original tubes back in the instrument.

If the response of the most sensitive range is abnormal, it must **first** be restored and this range rechecked. On the most sensitive range, a limited amount of adjustment at the higher frequencies (700 kc - 1 Mc) is available by means of L1, adjustable through an access hole in the front panel. Removal of the engraved escutcheon plate provides access to L1, R40, C2, C3 and C4. See Fig. 5. L1 should be adjusted (at 700 kc - 1 Mc) for the flattest response with respect to mid-band.

If the adjustment of L1 does not restore normal response the following components may be suspect: L1, C11, C15, C16, C19, R17, R18, R23, R24, R29, R36, CR2, and CR3.

If the response of the most sensitive range is normal ($\pm 0.5\%$ 10 cps to 500 kc, $\pm 0.75\%$ to 700 kc, $\pm 1.5\%$ to 1 Mc) and error exists on one or more of the attenuator ranges, the adjustments are as follows:

- a. 0.03 Volt Range — Adjust C2 for flattest response or best agreement with the most sensitive range.
- b. 0.3 Volt Range — Adjust C3 for flattest response or best agreement with the most sensitive range.
- c. 3.0 Volt Range — Adjust C4 for flattest response or best agreement with the most sensitive range. The adjustment on this range also takes care of the 30 and 300 Volt ranges.

If the above procedure fails to establish normal response on an attenuator range, capacitors C2, C3, C4, C5, C6 and C7 may be suspect. Access to these may be had by removal of the attenuator shield affixed to the rear of the attenuator switch by means of two machine screw nuts. Removal or replacement of capacitors C2, C3 and C4 is not possible without removal of the entire attenuator unit. If this appears necessary it is recommended that the instrument be returned to Ballantine Laboratories, Inc. for servicing.

5.3.5 Low Frequency Response

The low frequency response is determined solely by the amplifier, rectifier-meter portion of the instrument and hence is independent of range selector setting. This response is inherently flat and there are no controls or adjustments relating thereto.

To check the low frequency response connect together the instruments shown in Fig. 6. Set the signal generator to a frequency of 1,000 cycles and set the range selector on the instrument being checked and the level monitor to give on-scale deflections, noting the indication of each. Next set the signal generator to frequencies of 100, 30 and 10 cycles, in each case keeping the indication on the level monitor the same as it was at 1,000 cycles, and noting the indication of the instrument under test. This indication should be constant within $\pm 1\%$.

If this response is abnormal, the first attempt at correction should be tube replacement. In particular V1, V2, V3 and V4 should be checked for grid current. Abnormal grid current may be detected by voltages on grid number 1 which exceed those specified in Table IV under Section 5.4.2. Other components, which if defective, might lead to abnormal low frequency response are:

- a. Coupling capacitors C1, C14, C18, C20, C21, C23, and C25
- b. Bypass capacitors C12 and C24
- c. Decoupling capacitors C15A, B, C, C17A, B, C, and C22A
- d. Regulator tube V6.

5.3.6 SENS X10 Performance

For this function to operate properly the performance of the instrument in the checks outlined under 5.3.2, 5.3.3, 5.3.4 and 5.3.5 must be normal.

To check the SENS X10 performance connect a signal of mid-band (400 - 1000 cps) frequency to the input terminal of the Model 300H-U7 at a level of 300 microvolts. Set the range selector of the Model 300H-U7 to the 0.003 volt position and the function selector to the SENS X10 position. The indication should be $30 \pm 1\%$. If this is not obtained, adjust for an indication of precisely 30 by means of R40 available through an access hole in the front panel. See Fig. 5.

The frequency response in this function should be approximately as shown in Fig. 3 under Section 3.10 and may be checked by the procedure outlined under Sections 5.3.4 and 5.3.5.

5.4 Trouble Shooting

5.4.1 Equipment Required

- a. A stable, distortion-free, and accurately calibrated source of voltage with a signal frequency in the range of 400 to 1,000 cycles. The output of the source should be continuously variable over a range of at least 0.3 millivolt to 10 volts. The Ballantine Model 420 or Model 421A is such a source.
- b. A stable, distortion-free, variable frequency signal generator covering a range of at least 10 cycles to 1.0 Mc, the output of which should be variable over a range of at least 1 millivolt to 3 volts.
- c. A stable, sensitive, flat responding voltmeter covering a frequency range of at least 10 cycles to 1 Mc, and a voltage range of 1 millivolt to 1,000 volts. The Ballantine Model 300H-U7 is such a voltmeter.
- d. A volt-ohm-milliammeter exhibiting an input impedance of at least 10 megohms or higher when measuring dc voltages.

5.4.2 General Malfunction

In case of malfunction, as evidenced by insufficient or even absence of response, instability, high hum or noise level, intermittent operation or other disturbance, the first step is to check all tubes, replacing any which exhibit low gm, grid current, shorts, etc.

NOTE

VOLTAGES DANGEROUS TO HUMAN LIFE EXIST IN THIS EQUIPMENT. EXERCISE EXTREME CARE WHENEVER THE INSTRUMENT IS REMOVED FROM THE CASE.

With the tubes operating normally the voltage at the tube elements may be measured and checked against Table IV. All measurements should be made with the instrument input terminals short circuited and the range switch on the most sensitive range.

The instrument used to measure dc potentials should have an input resistance of not less than 10 megohms. Any radical departure (in excess of 15%) from the voltages indicated in Table IV may indicate the nature of the trouble.

In the event of a defective component it should be replaced in accordance with the Replacement Parts List located at the end of the manual. If the component or components are not available locally, they may be obtained from Ballantine Laboratories, Inc.

5.4.3 Signal Tracing

In the event that the procedure thus far fails to reveal the nature of the trouble, recourse may be made to signal tracing. The procedure is as follows:

- a. With the instrument on the 0.003 V range, connect a signal of 3 mV, 1,000 cycles to the input terminals.

TABLE IV

| TUBE ELEMENT POTENTIALS | | | | | | | |
|-------------------------|---------------------|--------|--------------------|--------------------|-------|--------|--------|
| Tube | Pin 1 | Pin 2 | Pin 3 | Pin 4 | Pin 5 | Pin 6 | Pin 7 |
| V1 6AU6 | 0 to ± 0.1 V | 1.35 V | 2.00 V | 4.10 V | 60 V | 70 V | 1.35 V |
| V2 6AU6 | 0 to ± 0.1 V | 1.35 V | *3.10 V | *3.10 V | 75 V | 92 V | 1.35 V |
| V3 6AU6 | 0 to -0.1 V | 1.35 V | *3.10 V | *3.10 V | 82 V | 95 V | 1.35 V |
| V4 6AU6 | 0 to ± 0.1 V | 1.55 V | *3.10 V | *3.10 V | 82 V | 122 V | 1.55 V |
| V5 OA2 | 150 V | 0 | — | 0 | 150 V | — | 0 |
| V6 6X4 | *360 V | — | *6.3 V to Pin 4 | *6.3 V to Pin 3 | — | *360 V | 390 V |

All measurements made with respect to chassis ground unless otherwise indicated. All voltages dc unless otherwise indicated. *ac voltages.

NOTE

IT IS POSSIBLE TO DAMAGE THE SIGNAL DIODES, IF THE PLATE OF V4 IS ACCIDENTALLY CONNECTED TO THE CHASSIS OR GROUND. IT IS ALSO POSSIBLE TO DAMAGE THE DIODES, METER, OR BOTH IF VIRTUALLY ANY PORTION OF THE MEYER RECTIFIER CIRCUIT IS GROUNDED. THE USER IS THEREFORE CAUTIONED TO TAKE EXTREME CARE WHEN MEASURING IN THIS SECTION OF THE INSTRUMENT.

- b. Measure the signal voltages at the plates of V1, V2, V3, and V4 using a sensitive, high input-impedance voltmeter such as the Ballantine Model 300H-017. When making these measurements precautions should be taken against introducing spurious signals into high impedance circuits. Operating the instrument on a grounded plate with the operator making contact with this ground should be sufficient.

NOTE

BECAUSE OF THE PRESENCE OF HIGH VOLTAGES, DO NOT MAKE CONTACT WITH GROUND UNTIL THE DESIRED CONNECTION HAS BEEN MADE AND THE HAND REMOVED THEREFROM. OBSERVE SAME PRECAUTION WHEN REMOVING CONNECTIONS.

Compare the voltages measured with those listed on the schematic diagram located at the rear of this manual (Fig. 7). Any radical departure (greater than +10%) from the voltages shown may indicate the nature of the trouble.

5.4.4 Power Supply Malfunction

The power supply of this instrument is of extremely simple design and, except for vacuum tube (V5, V6)

replacement, should seldom if ever cause any trouble. The diodes (CR4, CR5) employed in the dc heater supply are of the hermetically sealed silicon junction type and have a virtually limitless life.

On the schematic diagram located at the rear of this manual are the pertinent dc, ac and ripple (for both 60 cycles and 400 cycles operation) potentials. Measurements of these should be made with zero signal input, and the instrument range knob set to 300 volts. Any radical departure from these potentials may indicate the nature of the trouble.

5.4.5 Trouble Shooting Chart

To assist in trouble shooting, a chart has been prepared which lists symptoms, possible cause and/or remedy, and where possible, a reference to a pertinent section of this manual.

TROUBLE SHOOTING CHART

| Symptom | Possible Cause and/or Remedy | Pertinent Sections |
|--|---|--------------------|
| Instrument inoperative | Fuse blown | 5.1.1 |
| | ON-OFF switch | |
| | Line cord defective | |
| | Power supply defective | 5.4.4 |
| | Vacuum tubes V1, V2, V3, V4 | |
| | Amplifier component | 5.4.3 |
| | Signal diode CR2, CR3 | 4.3 |
| | Meter | 4.3 |
| Capacitor C24 | 4.3 | |
| Erratic meter indication | Vacuum Tubes V1, V2, V3, V4, V5, V6 | |
| | Attenuator switch or component | 4.1, 5.4.3 |
| | Amplifier component | 4.2, 5.4.3 |
| | Power supply component | 4.4, 5.4.4 |
| Meter indicating with zero input signal | Excessive heater-cathode leakage V1, V2, V3, V4 | |
| | Capacitor C25 | |
| | Resistor R43 or R44 | 4.3 |
| | Amplifier oscillating | 4.2, 5.4.3 |
| Microphonics | V1 excessively microphonic | |
| | Imperfectly solder connection | |
| | Poor electrical contact in range switch | |
| Excessive hum (meter beats when signals near line frequency or harmonics are measured) | Excessive heater-cathode leakage V1, V2, V3, V4 | |
| | Instrument being operated in strong magnetic field of another instrument or equipment | |
| | Ground current flowing in signal carrying lead | 3.6 |
| | | |

TROUBLE SHOOTING CHART Continued

| Symptom | Possible Cause and/or Remedy | Pertinent Sections |
|--|--|--------------------------|
| Scale adjustment off — impossible to correct by means of R43 | Vacuum tube V1, V2, V3, V4 Diode CR2, CR3 Resistor R43, R44 Capacitor C23, C24, C25 | 4.3, 5.3.2 |
| Range switch does not decade | Resistor R1, R2, R3, R4, R5, R6, R7, R8 Capacitor C2, C3, C4, C5, C6, C7, C8 Amplifier tube V1 (excessive grid current) | 4.1, 5.3.1 4.1, 5.3.2 |
| Accuracy off — adjustment of R10 does not correct | Attenuator resistor R1, R2, R3, R4, R5, R6, R7, R8 Scale adjustment not properly made Amplifier tube V1, V2, V3, V4 Defective diode CR2, CR3 Meter M1 | 4.1, 5.3.1 4.1, 5.3.2 |
| Abnormal high frequency response | Amplifier tube V1, V2, V3, V4 Diode CR2, CR3 Capacitor C2, C3, C4, C5, C6, C7, C11, C15, C16, C19 | 4.3 4.2, 5.3.4 |
| Abnormal low frequency response | Amplifier tube V1, V2, V3, V4 Capacitors C1, C12, C14, C18, C20, C21, C23, C24, C25, C13A, B, C, C17A, B, C, C22A Diode CR2, CR3 | 4.2, 5.3.5 |

6. SHIPPING INSTRUCTIONS

If it should be necessary to return the instrument to Ballantine Laboratories, Inc. make certain that at least four inches of padding material surrounds the instrument to prevent damage during shipment. Ship via REA Express, motor truck, or air freight, to

Ballantine Laboratories, Inc.
90 Fanny Road
Boonton, New Jersey

7. REPLACEMENT PARTS LIST

REFER TO MODEL 300H-U7 SCHEMATIC DIAGRAM, ISSUE MD-3-151A

| <i>B. L. Part No.</i> | <i>Circuit Symbol</i> | <i>Capacitors</i> | <i>Manufacturer</i> |
|---------------------------|---------------------------|---|---------------------|
| 2388 | C1 | 0.033 μ F, 5%, 600 V, Type 355E333J | Gudeman |
| 2439 | C2 | 1.4-7.3 pF, 850 V, Type 189-3-5 | Johnson |
| 2439 | C3 | 1.4-7.3 pF, 850 V, Type 189-3-5 | Johnson |
| 2439 | C4 | 1.4-7.3 pF, 850 V, Type 189-3-5 | Johnson |
| 9000 | C5 | 3300 pF, 5%, 33 V, Type 611 | Mial |
| 9005 | C6 | 33 μ F, 5%, 630 V, Type 611 | Mial |
| 9002 | C7 | 350 pF, 5%, 160 V, Type 611 | Mial |
| 9004 | C11 | 50 μ F, 5%, 160 V, Type 611 | Mial |
| 7834 | C12 | 320 μ F, 25 V, Type C426 | Amperex |
| 2042 | C13A | 50 μ F, 150 V, Type FP | Mallory |
| | C13B | 50 μ F, 150 V, Type FP | Mallory |
| | C13C | 50 μ F, 150 V, Type FP | Mallory |
| 8122 | C14 | 0.22 μ F, 10%, 200 V, Type C296 | Amperex |
| 9006 | C15 | 70 pF, 5%, 160 V, Type 611 | Mial |
| 9001 | C16 | 620 pF, 5%, 33 V, Type 611 | Mial |
| 2042 | C17A | 50 μ F, 150 V, Type FP | Mallory |
| | C17B | 50 μ F, 150 V, Type FP | Mallory |
| | C17C | 50 μ F, 150 V, Type FP | Mallory |
| 8122 | C18 | 0.22 μ F, 10%, 200 V, Type C296 | Amperex |
| 9003 | C19 | 250 pF, 5%, 33 V, Type 611 | Mial |
| 8122 | C20 | 0.22 μ F, 10%, 200 V, Type C296 | Amperex |
| 8123 | C21 | 0.01 μ F, 10%, 200 V, Type C296 | Amperex |
| 2043 | C22A | 10 μ F, 500 V, Type FP | Mallory |
| | C22B | 10 μ F, 500 V, Type FP | Mallory |
| | C22C | 10 μ F, 500 V, Type FP | Mallory |
| 8124 | C23 | 1 μ F, 10%, 200 V, Type C296 | Amperex |
| 7835 | C24 | 25 μ F, 25 V, Type C426 | Amperex |
| 8124 | C25 | 1 μ F, 10%, 200 V, Type C296 | Amperex |
| 8124 | C26 | 1 μ F, 10%, 200 V, Type C296 | Amperex |
| 9002 | C27 | 330 pF, 5%, 160 V, Type 611 | Mial |
| 2757 | C30 | 1000 μ F, -10% +150%, 25 V, Type FP | Mallory |
| <i>Resistors</i> | | | |
| 8814 | R4 | 200,000 ohms, 1%, Type MF6C | Electra |
| 8815 | R5 | 20,200 ohms, 1%, Type MF6C | Electra |
| 8817 | R6 | 1,800 ohms, 1%, Type MF6C | Electra |
| 8818 | R7 | 180 ohms, 1%, Type MF6C | Electra |
| 1088 | R9 | 68 ohms, 10%, Type EB | Allen-Bradley |
| 1932 | R10 | 1,000 ohms, -30%, Type PM-45 | CTS |
| 1071 | R11 | 47 ohms, 10%, Type EB | Allen-Bradley |
| 1148 | R12 | 2,000 ohms, 5%, Type BB 305 05A | Amperex |
| 8805 | *R13 | 224 ohms, 1%, Type MF6C | Electra |
| 1058 | R14 | 1,000 ohms, 10%, Type EB | Allen-Bradley |
| 1775 | R15 | 2.30 ohms, -1%, Special | Ballantine |

*In some instruments the component listed may not be used at all or its value may differ from the value shown.

REPLACEMENT PARTS LIST (Continued)

REFER TO MODEL 300H-U7 SCHEMATIC DIAGRAM, ISSUE MD-3451A

| <i>B. L. Part No.</i> | <i>Circuit Symbol</i> | <i>Resistors</i> | <i>Manufacturer</i> |
|---------------------------|---------------------------|---------------------------------------|---------------------|
| 1038 | R16 | 27,000 ohms, 10%, Type EB | Allen-Bradley |
| 8820 | R17 | 47,000 ohms, 1%, Type MF6C | Electra |
| 1147 | R18 | 5,100 ohms, 5%, Type BB 305 05A | Amperex |
| 1025 | R19 | 120,000 ohms, 10%, Type EB | Allen-Bradley |
| 1009 | R20 | 1,500,000 ohms, 5%, Type EB | Allen-Bradley |
| 1090 | R21 | 510 ohms, 5%, Type BB 305 05A | Amperex |
| 1144 | R22 | 15,000 ohms, 10%, Type EB | Allen-Bradley |
| 1145 | R23 | 12,000 ohms, 10%, Type EB | Allen-Bradley |
| 1146 | R24 | 7,500 ohms, 5%, Type BB 305 05A | Amperex |
| 1103 | R25 | 22,000 ohms, 10%, Type EB | Allen-Bradley |
| 1010 | R26 | 1,000,000 ohms, 5%, Type EB | Allen-Bradley |
| 1149 | R27 | 390 ohms, 10%, Type BB 305 05A | Amperex |
| 1146 | R28 | 7,500 ohms, 5%, Type BB 305 05A | Amperex |
| 1041 | R29 | 18,000 ohms, 5%, Type EB | Allen-Bradley |
| 1038 | R30 | 27,000 ohms, 10%, Type EB | Allen-Bradley |
| 1008 | R31 | 2,000,000 ohms, 5%, Type EB | Allen-Bradley |
| 1008 | R32 | 2,000,000 ohms, 5%, Type EB | Allen-Bradley |
| 1025 | R34 | 120,000 ohms, 10%, Type EB | Allen-Bradley |
| 8950 | R35 | 300 ohms, 5%, Type BB 305 05A | Amperex |
| 1041 | R36 | 18,000 ohms, 5%, Type EB | Allen-Bradley |
| 8951 | R37 | 200 ohms, 5%, Type BB 305 05A | Amperex |
| 1144 | R38 | 15,000 ohms, 10%, Type EB | Allen-Bradley |
| 1027 | R39 | 100,000 ohms, 10%, Type EB | Allen-Bradley |
| 1933 | R40 | 200 ohms, $\pm 30\%$, Type PM-45 | CTS |
| 8821 | R41 | 800 ohms, 1%, Type MF6C | Electra |
| 8822 | R42 | 85 ohms, 1%, Type MF6C | Electra |
| 1927 | R43 | 500,000 ohms, $\pm 30\%$, Type PM-45 | CTS |
| 1001 | R44 | 10,000,000 ohms, 10%, Type EB | Allen-Bradley |
| 8812 | R45 | 215 ohms, 1%, Type MF6C | Electra |
| 8952 | R50 | 100 ohms, 10%, Type EB | Allen-Bradley |
| 8950 | R51 | 300 ohms, 5%, Type BB 305 05A | Amperex |
| 6164 | R52 | 4,000 ohms, 5%, Type 244E4025 | Sprague |
| 6164 | R53 | 4,000 ohms, 5%, Type 244F4025 | Sprague |
| 6070 | R60 | 1,000,000 ohms, 1%, Type MF6C | Electra |
| 8813 | R61 | 800,000 ohms, 1%, Type MF6C | Electra |
| 6070 | R62 | 1,000,000 ohms, 1%, Type MF6C | Electra |
| 6070 | R63 | 1,000,000 ohms, 1%, Type MF6C | Electra |
| 6070 | R64 | 1,000,000 ohms, 1%, Type MF6C | Electra |
| 8816 | R65 | 998,000 ohms, 1%, Type MF6C | Electra |
| 8819 | R66 | 40 ohms, 1%, Type MF5C | Electra |
| 8819 | R67 | 40 ohms, 1%, Type MF5C | Electra |

REPLACEMENT PARTS LIST (Continued)

REFER TO MODEL 300H-U7 SCHEMATIC DIAGRAM, ISSUE MD-3451A

| <i>B. L. Part No.</i> | <i>Circuit Symbol</i> | <i>Other Components</i> | <i>Manufacturer</i> |
|---------------------------|---------------------------|-------------------------------|---------------------|
| 3144 | CR1 | Diode, Type 553G | Transitron |
| 3144 | CR2 | Diode, Type 553G | Transitron |
| 3144 | CR3 | Diode, Type 553G | Transitron |
| 7921 | CR4 | Rectifier, Type 36591 | RCA |
| 7921 | CR5 | Rectifier, Type 36591 | RCA |
| 3410 | F1 | Fuse, 0.4 A, Type MDL Slo-Blo | Bussmann |
| 3475 | IL | Pilot Light, Type 1815, 12 V | General Electric |
| 3023 | L1 | Variable Inductor, Special | Ballantine |
| 6022 | M1 | Meter, Indicating | Ballantine |
| 3283 | S1 | Switch, Attenuator, Special | Ballantine |
| 3282 | S2 | Switch, Function, Special | Ballantine |
| 3059 | T1 | Power Transformer | Ballantine |
| 7907 | V1 | Tube, Type 6AU6A, Code 16 | RCA |
| 7907 | V2 | Tube, Type 6AU6A, Code 16 | RCA |
| 7907 | V3 | Tube, Type 6AU6A, Code 16 | RCA |
| 7907 | V4 | Tube, Type 6AU6A, Code 16 | RCA |
| 3105 | V5 | Tube, Type 6X4 | RCA |
| 3106 | V6 | Tube, Type 6A2 | RCA |
| 4139 | — | AC Power Cord | Ballantine |

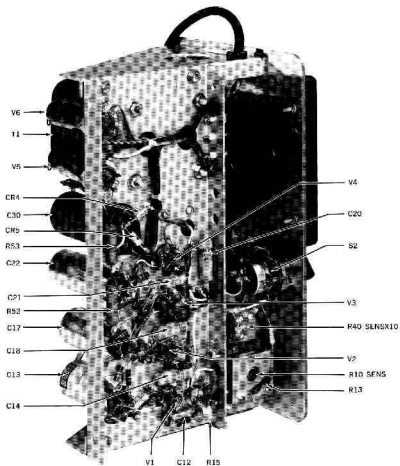

Fig. 7. Ballantine Model 300H-U7
Interior View, Left Side

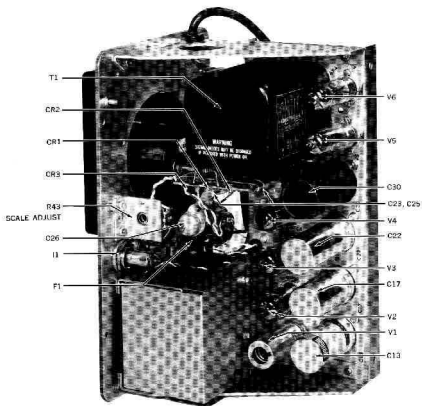
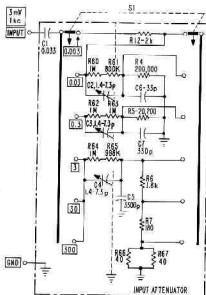
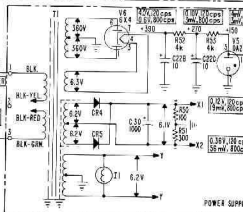
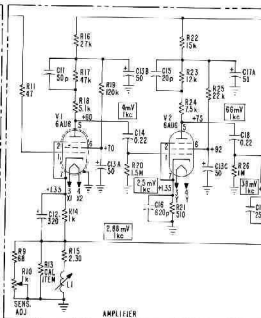
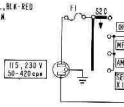

Fig. 8. Ballantine Model 300H-U7
Interior View, Right Side



115V OPERATION: F1 - 0.4 AMP. SLD - BLU.
 TERM. 1 - BLK, BLK - RFD.
 TERM. 3 - BLK - YEL, BLK - GRN.
 230V OPERATION: F1 - 0.2 AMP. SLD - RIG.
 TERM. 1 - BLK.
 TERM. 2 - BLK - YEL, BLK - RED
 TERM. 3 - BLK - GRN



CAPACITORS: NOT MARKED - MICROFARADS (10⁻⁶F)
 P - PICO FARADS (10⁻¹²F)
 RESISTORS: NOT MARKED - OHMS (Ω)
 K - KILOHMS (10³Ω)
 M - MEGOHMS (10⁶Ω)
 VOLTAGES: NOT MARKED - VOLTS (V)
 mV - MILLIVOLTS (10⁻³V)

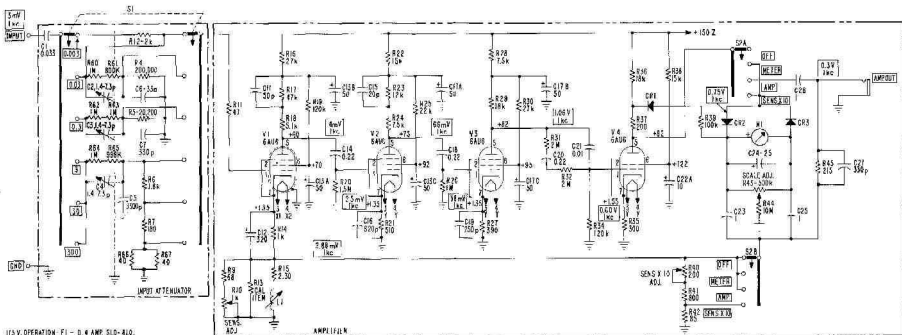

115 V. OPERATION - F1 - D 4 AMP. SLD - 810.
 TERM 1 - BLK. BLK - RED
 TERM 2 - BLK - YEL. B1 CRN
 250 V. OPERATION - F1 - D 2 AMP. SLD - 819
 TERM 1 - BLK
 TERM 2 - BLK - YEL. BLK - RED
 TERM 3 - BLK - GRN

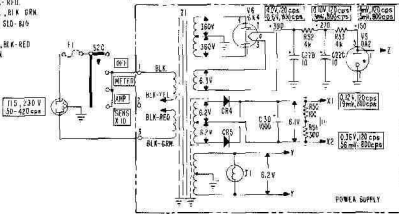

CAPACITORS NOT MARKED - MICROFARADS (10⁻⁶F)
 M - MICROFARADS (10⁻⁶F)
 RESISTORS NOT MARKED - OHMS (Ω)
 K - KILOHMS (10³Ω)
 M - MEGOHMS (10⁶Ω)
 VOLTAGES NOT MARKED - VOLTS (V)
 MV - MILLIVOLTS (10⁻³V)

FIG. 9. SCHEMATIC DIAGRAM, ISSUE No. MD-3457A
 MODEL 300H-U7 SENSITIVE ELECTRONIC VOLTMETER
 BALLANTINE LABORATORIES, INC.
 Boonton, New Jersey

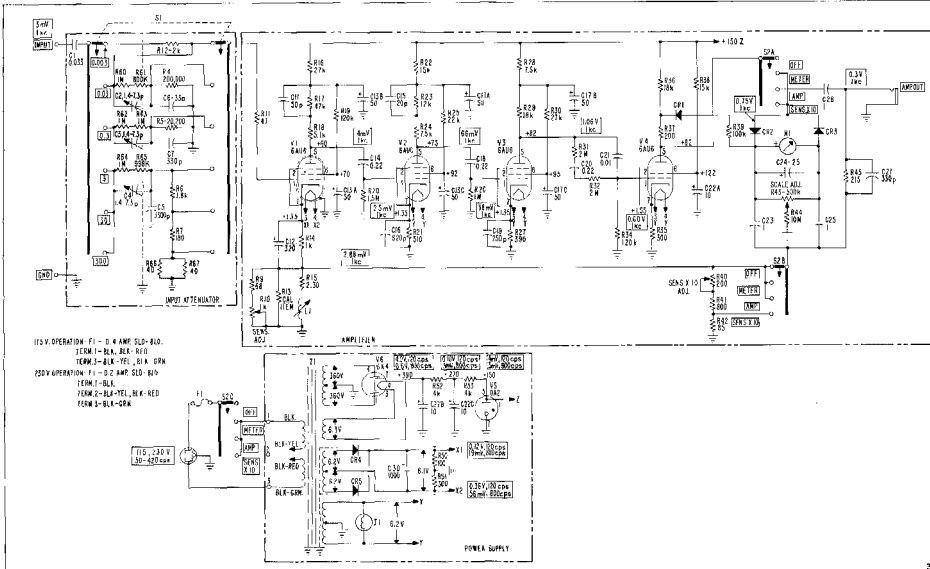

115 V. OPERATION: F1 - D-4 AMP. SLD-810.
 TERM. 1 - BLK. BLK-RED
 TERM. 2 - BLK-YEL. B1 & GRN
 250 V. OPERATION: F1 - D-2 AMP. SLD-810
 TERM. 1 - BLK
 TERM. 2 - BLK-YEL. BLK-RED
 TERM. 3 - BLK-GRN

CAPACITORS NOT MARKED - MICROFARADS (10⁻⁶ F)
 MICROFARADS (10⁻⁴ F)
 RESISTORS NOT MARKED - OHMS (Ω)
 K - KILOHMS (10³ Ω)
 M - MEGOHMS (10⁶ Ω)
 VOLTAGES NOT MARKED - VOLTS (V)
 MV - MILLIVOLTS (10⁻³ V)

FIG. 9. SCHEMATIC DIAGRAM, ISSUE No. MD-3451A
 MODEL 300H-U7 SENSITIVE ELECTRONIC VOLTMETER
 BALLANTINE LABORATORIES, INC.
 Boonton, New Jersey

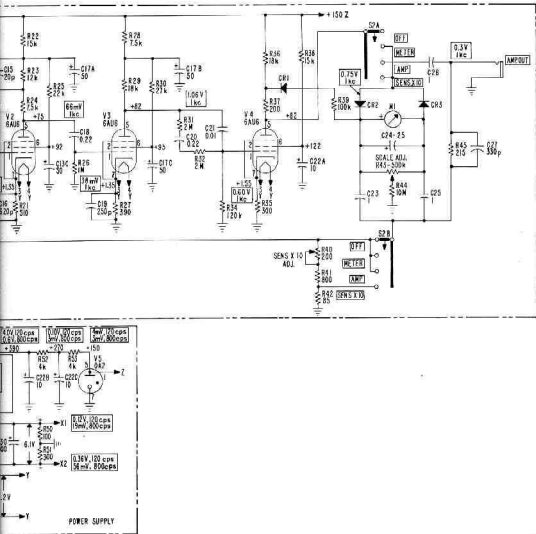

FIG. 9. SCHEMATIC DIAGRAM, ISSUE No. MD-3451A
MODEL 300H-U7 SENSITIVE ELECTRONIC VOLTMETER

BALLANTINE LABORATORIES, INC.
Boonton, New Jersey